

# Polaris

120 minutes datamedia protection to the HIGHEST test standards



Model above is  
D570



Losing your datamedia means that its invaluable contents are often left in the wrong hands. Such data could be priceless artwork, client payment details or even patient history. Inevitably, the long term outcomes of such a theft could be the loss of clients or more importantly, the closure of the business.

With the Rosengrens Polaris you can be assured all your datamedia will be fully protected against theft or fire. This new generation cabinet takes data protection to higher levels of luxury and appeal. Its boasts a stunning and dynamic look with the new three spoke handle. Its product features just don't lie on the outside. Constructed from the highest specification materials, the cabinet offers 2 hours fire protection, high quality locking and can be customised with a wide range of fittings. With all of these features packed into a cabinet, its no surprise the Polaris is the top of the datamedia protection range...

# Polaris

120 minutes datamedia protection to the HIGHEST test standards

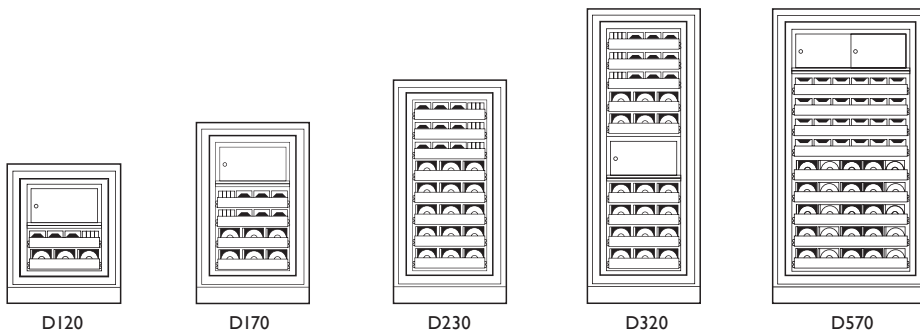

| Product data     |                     |       |        |                     |       |       |                   |               |                      |                |
|------------------|---------------------|-------|--------|---------------------|-------|-------|-------------------|---------------|----------------------|----------------|
| Model<br>Polaris | Ext Dimensions (mm) |       |        | Int Dimensions (mm) |       |       | Weight**<br>(kgs) | Vol.<br>(lit) | Fittings<br>Supplied | Fire<br>Rating |
|                  | Height              | Width | Depth* | Height              | Width | Depth |                   |               |                      |                |
| D120             | 920                 | 750   | 720    | 570                 | 490   | 400   | 318               | 115           | Empty                | 120            |
| D170             | 1200                | 750   | 720    | 850                 | 490   | 400   | 395               | 171           | Empty                | 120            |
| D230             | 1480                | 750   | 720    | 1130                | 490   | 400   | 495               | 227           | Empty                | 120            |
| D320             | 1950                | 750   | 720    | 1580                | 490   | 400   | 645               | 316           | Empty                | 120            |
| D570             | 1950                | 1040  | 770    | 1580                | 780   | 460   | 865               | 577           | Empty                | 120            |

\* Projection of handle is 65mm \*\*Weights without interior fittings and packing.

**Fire protection:** The Rosengrens Polaris series has been tested and approved to EN 1047-1 and certified by ECB•S to the fire resistance of S120DIS, which means 2 hours' fire protection. The range also holds an American UL certificate to the Class 125 2 H with fire and impact, which means 2 hours' fire protection.

**Burglary protection:** The Polaris cabinets are tested in accordance with the European norm EN 14450 and certified by ECB•S in security classes S1 and S2.

**Lock:** All Polaris data safes are secured by the Rosengrens resettable RKL-10 key lock as standard. Alternative locking includes electronic or dual locking options.

**Design:** The design is functional and elegant with a light colour scheme, built-in hinges and a functional handle with push and seal closure as standard. Thanks to the cabinets smaller external dimensions in relation to capacity the cabinets blend in well with most environments.

**Quality and environmental management systems:** The Rosengrens Polaris series are all manufactured in accordance with the ISO 9001 quality management system and the ISO 14000 environmental management system.

**Rosengrens Product Guidelines:** The construction of Polaris has been tested and approved to the Rosengrens Product Guidelines which are based on all relevant European norms. The aim is to verify the user friendliness, safety and product lifetime, thereby assuring customers that our products live up to the highest expectations.

| Maximum storage capacity of data media |            |             |      |  |         |         |         |         |  |
|--|------------|-------------|------|--|---------|---------|---------|---------|--|
| Type of data media                     | Size in mm | Media/shelf |      | Total number of data media/number of shelves |         |         |         |         |  |
|  |            | D120 - D320 | D570 | D120   | D170    | D230    | D320    | D570    |  |
| CD/DVD                                 | 142x124x10 | 117         | 225  | 468/4  | 702/6   | 936/8   | 1404/12 | 2700/12 |  |
| Zip drives                             | 103x104x12 | 128         | 250  | 640/5  | 896/7   | 1280/10 | 1792/14 | 3500/14 |  |
| DLT/LTO tapes                          | 110x112x30 | 48          | 94   | 192/4  | 336/7   | 432/9   | 624/13  | 1222/13 |  |
| DAT cassettes                          | 80x60x15   | 134         | 260  | 1072/8                                       | 1608/12 | 2144/16 | 3216/24 | 6240/24 |  |

**Contact Details:**

Warwick Fraser & Co Ltd  
Unit 9, Alford Business Centre  
Lorwood Road  
Alford, Cranleigh  
Surrey GU6 8HP  
Tel: 01403 753069  
Fax: 01403 752469



E-mail: [sales@warwickfraser.co.uk](mailto:sales@warwickfraser.co.uk)  
[www.warwickfraser.co.uk](http://www.warwickfraser.co.uk)

**Interior fittings**

All fittings are adjustable on each 10 mm



**Fixed shelf**  
For D120 – D320  
Size 17x474x395  
For D570  
Size 17x764x445

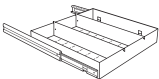

**Extensible flexible shelf**  
For D120 – D320  
Size 60x434x392  
includes 2 dividers & 9 tilt supports  
For D570  
Size 60x724x452  
includes 4 dividers & 15 tilt supports

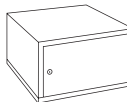

**Lockable compartment**  
For D120 – D320  
Size 275x474x380

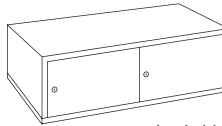

**Lockable double compartment**  
For D570  
Size 275x764x440

**Interior fittings**

All fittings are adjustable on each 10 mm

**Fixed shelf**  
For D120 – D320  
Size 17x474x395  
For D570  
Size 17x764x445

**Extensible flexible shelf**  
For D120 – D320  
Size 60x434x392  
includes 2 dividers & 9 tilt supports  
For D570  
Size 60x724x452  
includes 4 dividers & 15 tilt supports

**Lockable compartment**  
For D120 – D320  
Size 275x474x380

**Lockable double compartment**  
For D570  
Size 275x764x440